

head office: Unit 15, 2/F., Kin Fat Industrial Centre, Kin Fat Street, Tuen Mun, Hong Kong SAR, China **tel:** +852 2465 9323 **fax:** +852 2456 1364
sales office: 8/F., Golden Name Commercial Building, 400 Portland Street, Mongkok, Hong Kong SAR, China **tel:** +852 2465 9122 **fax:** +852 2465 9199
email: info@chungtai-rs.com.hk **world wide web:** http://www.chungtai-rs.com.hk

Speciality of Chung Tai Fire Rated Air Louver:

Patent Information

Fire rated louvre type ventilator - HK 1051463

Fire rated louvre type ventilator - ZL 02282158.9

(China Utility Model Patent)

Chung Tai fire rated air louver – tested in BRANZ, New Zealand

Chung Tai fire rated air louver – tested in accordance with BS476, Part 22, Clause 8 and provides 4 hrs integrity. Maximum height is 2900mm from the floor level.

Chung Tai fire rated air louver – there is expansion gap between the louver and outer frame. It can provide space for steel to expand due to the high temperature in fire and hence would not cause destruction in its structure.

Due to the rise of hot air in fire, a negative pressure region will be formed at 1000mm from the floor level. Cold air will keep flowing in the region through louver hence to prevent smoke and fire from flowing out.

Chung Tai fire rated air louver – during the fire test the engineer in charge set the 1000mm from the floor level into a positive pressure region. This is the air pressure simulation of 2900mm from the floor level in fire. And our louver still could prevent smoke and fire from flowing out during the fire test.

Chung Tai fire rated air louver –
42% air flow at 1000mm from F.F.L.
23% air flow at 2900mm from 1000mm

Chung Tai fire rated air louver – outer frame is 47mm.

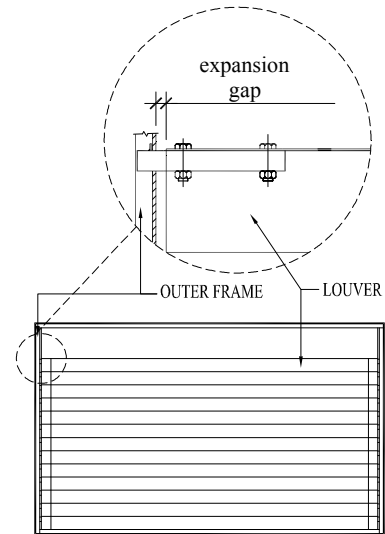

PICTURE 1

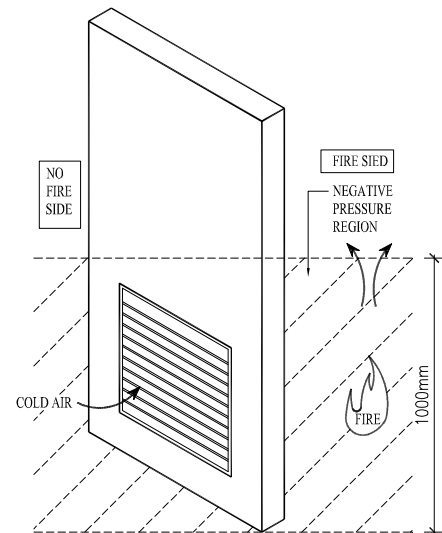

PICTURE 2

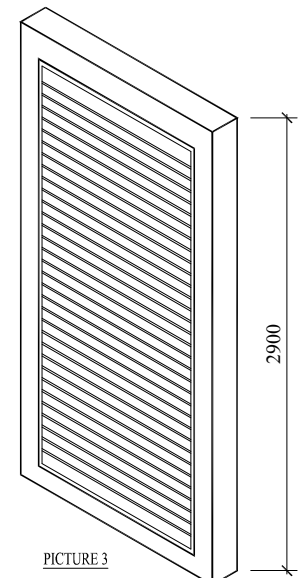

PICTURE 3

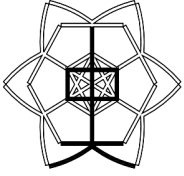

Chung Tai Roller Shutters Co. Ltd.

中大捲閘有限公司



ISO 9001 2000
Certificate No CC 1484

head office: Unit 15, 2/F., Kin Fat Industrial Centre, Kin Fat Street, Tuen Mun, Hong Kong SAR, China **tel:** +852 2465 9323 **fax:** +852 2456 1364
sales office: 8/F., Golden Name Commercial Building, 400 Portland Street, Mongkok, Hong Kong SAR, China **tel:** +852 2465 9122 **fax:** +852 2465 9199
email: info@chungtai-rs.com.hk **world wide web:** <http://www.chungtai-rs.com.hk>